



IMET SPA
Località tre fontane, 6 - 24034
Cisano Bergamasco (BG) Italy
Tel +39 035 4387911 | Fax +39 035 787066
imet@imetsaws.com
www.imetsaws.com

MACHINE MODEL

KS 652 NC

Segatrice semiautomatica con rotazione automatica

Short description

La segatrice è lo strumento di lavoro ideale per carpenterie, produttori di telai e acciai da costruzione ed è in grado di tagliare da +60° a -60° con rotazione, movimentazione dell'arco motorizzata e controllata tramite touch screen 7". La discesa dell'arco è idraulica a doppio montante e alta pressione della lama per ottimizzare le performance di taglio.



Cutting capacity at 0°	Tondo: 510mm - Quadrato: 480mm - Rettangolo: 650x450mm
Cutting capacity at 45° left	Tondo: 440mm - Quadrato: 430mm - Rettangolo: 430x430mm
Cutting capacity at 45° right	Tondo: 440mm - Quadrato: 440mm - Rettangolo: 440x440mm
Cutting capacity at 60° left	Tondo: 250mm - Quadrato: 250mm - Rettangolo: 250x450mm
Cutting capacity at 60° right	Tondo: 250mm - Quadrato: 250mm - Rettangolo: 250x450mm
Cutting capacity with bundle	Max: 650x450mm - Min: 125x15mm
Cutting capacity at 0°, solids (C45)	280mm (350mm with High Performance pack)
Minimum scrap-end with bundle	250mm
Blade motor	3KW (4 KW)
Blade speed	15 - 100 m/min
Blade size	5320x34x1.1mm (41mm)
Blade tension	2000kg/cm2
Sawframe rotation	0.55KW
HMI and panel control	Touch screen 7" with NC
Size	1895x2870x2300mm - 2100kg

Features



Hydraulic vice

The fixed vice slides transversely on the work surface with linear guides and is complete with a pressure reducer as standard. Displacement by hydraulic cylinder, controlled by encoder and hydraulic brake. The vice is also equipped with an automatic control system for the size of the piece via encoder.

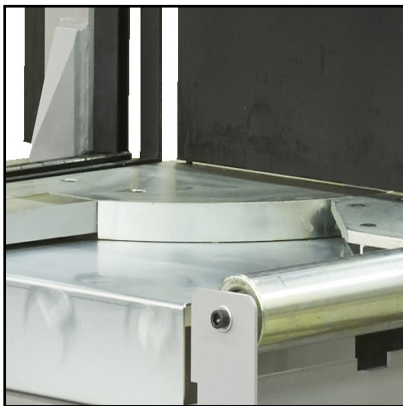

Wide working area

Ease of use is ensured thanks to the large work surface with rotation integral with the bow and blade passage to optimize the penetration of the material. The electro-welded steel structure guarantees absence of vibrations and maximum support of the material during cutting.



Sawframe

Machine's sawframe is electrowelded with rigid structure and big thickness. The massive structure helps reduce vibrations, binding or slowing during the cutting process, saving sawblade life and durability. High cutting performances even on the biggest sections and full materials are provided by the canted blade.

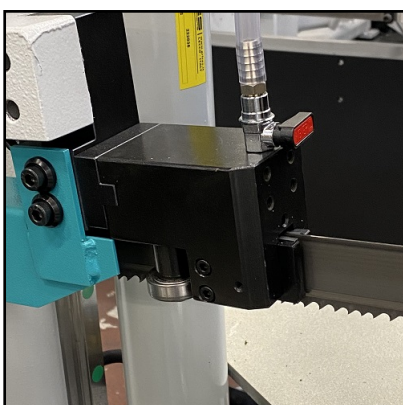

Blade tension

The blade of KS 652 has a tension of 2000 kg / cm² and is equipped with a control microswitch for stopping immediately the blade in case of breaking or tension failure. The machine is equipped with blade guide sliding on linear guides for easy adjustment with hard metal inserts and additional bearings to improve alignment



Optimized cutting process

The inclined blade allows the work cycle to be optimized: the blade is in fact never parallel to the surface and is never (not even in the case of a square tube) working on a solid surface, but always on a section of the material, even during cutting the final part of the bar. This helps save unnecessary stress on the tape, safeguarding its lifespan.



Motorized rotation

The automatic sawframe rotation is managed by motor reducer and inverter. An hydraulic piston lock the bow once it reached the set position. To keep clean and allows perfect rotation, an air-cleaning system is working during the rotation. Bow rotation power is 0.55KW.



Sawframe descent

KS 652 NC sawframe descent is idraulic with easy regulation by two handlers positioned on the mobile independent consolle. The machine also mounts a mechanic detection device to ease the blade approach to the material and detect the first cut point.



HMI interface

KS 652 NC's an easy and intuitive interface dedicate do optimize the user-experience: thanks the CNC system and 7" touch screen display, the user can manage all the machine operative function, set up 99 cutting program and multiple cutting length on the same bar, set the number of feeder stroke, the number of pieces and blade speed. It's also possibile to do an autodiagnostic to detech errors.



Hydraulic unit

The hydraulic system of the saw is made up of a block complete with valves for: translation vice, locking vice, closing vice and rotation brake. The system is equipped with a cylinder connection and is supplied complete with a control unit with a 0.55KW motor.



Blade cleaning

Motorized nylon cleaning brush for blade, driven by motor pulley to always keep in perfect condition rivo di the cutting blade.



High performance pack

OPTIONAL

It's possibile to extend the machine cutting performances, like the cutting capacity at 90° of full solid bars by adding the dedicated pack that includes: 4kw Bonfiglioli motor, 41mm h. blade and hydraulic tensioning system. The pack also improves KS 652 NC performances on big size diameters.

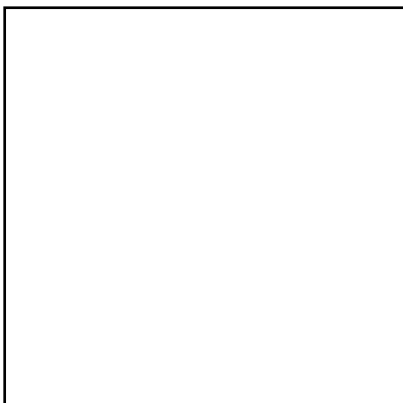

Bundle cuttg device

OPTIONAL

The bundle cutting device is required when working with bundles of tubes or profiles. Adding the device will change a little bit the machine cutting capacity: max. 650x450mm, min. 125x15mm. When the device is mounted, the machine can only cut at 0°; if the user needs to cut with different angle, the device must be disassembled



Minimal lubrication **OPTIONAL**

The lubrication system cancels the dispersion of the coolant without damaging or affecting the life of the blade. The system is equipped with a 1.3l tank and nozzle.



Laser **OPTIONAL**

It's available a laser ray that points the set cutting line on the material, improving the user's workflow.



Loading-unloading roller table **OPTIONAL**

Compatible with infeed and outfeed side, the roller table is made a single module of 1.5m length with 1 pedestal. Max capacity 1500kg. It's possibile to add an extra pedestal to install it stand-alone from the machine



Digital reading unloading table **OPTIONAL**

Unloading side roller table equipped with digital reading length stop with manual positioning. The RTL table is available with 3, 6 and 9 metres length.

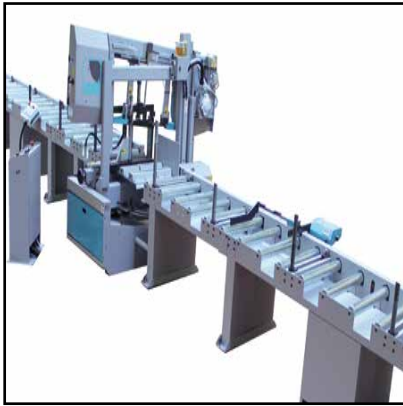

Loading motorized roller table **OPTIONAL**

Loading motorised roller tables, with chain transmission and motor reducer managed by inverter, with mobile keyboard. Available : -3m, loading 3000kg; -6m, loading 6000kg; -9m, loading 9000kg; -12m, loading 12000kg.



Unloading motorized roller tables **OPTIONAL**

Unloading motorised roller tables, with chain transmission and motor reducer managed by inverter, with mobile keyboard. Available : -3m, loading 3000kg; -6m, loading 6000kg; -9m, loading 9000kg; -12m, loading 12000kg.

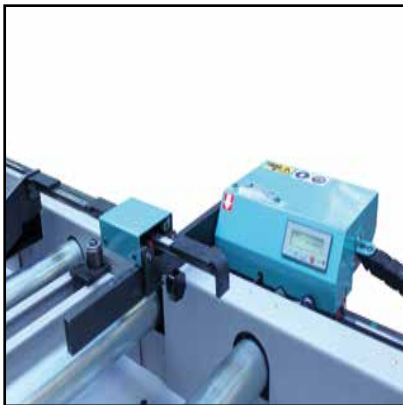

Digital length stop RL **OPTIONAL**

Digital reading length stop with manual positioning with automatic slowdown sensors, available only together with unloading motorized roller table - Measuring length 3m; Measuring length 6m; Measuring length 9m; Measuring length 12m



Motorized length stop RR **OPTIONAL**

Numerical control motorized measurement RR with fast approaching for automatic slowdown of the automatico del piece (to be ordered coupled with automatic conveyors) -Measuring length 6m; Measuring length 9m; Measuring length 12m



Single vertical roller

OPTIONAL

Single vertical roller, height of 250 mm. to prevent falls, max 2 each 1,5 mt5m



Pair of vertical rollers

OPTIONAL

Pair of containment vertical rollers, made in steel, max 2 pairs for each element 1,5 mt long

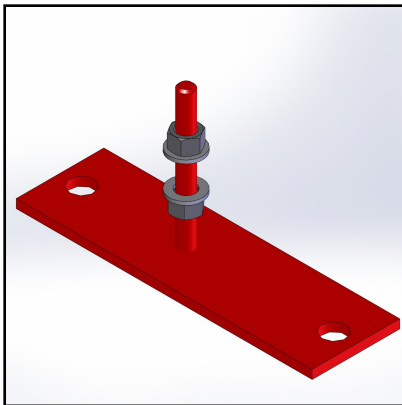

Additional foot in kit for machine

OPTIONAL

Additional foot in kit, to be used to fix the machine to ground once positioned.

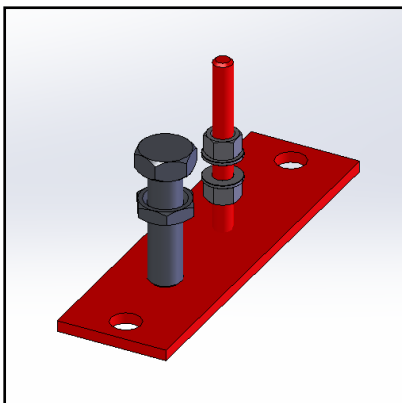

Additional foot in kit for roller tables

OPTIONAL

Additional foot in kit, to be used to fix the tables to ground once positioned.