



IMET SPA
Località tre fontane, 6 - 24034
Cisano Bergamasco (BG) Italy
Tel +39 035 4387911 | Fax +39 035 787066
imet@imetsaws.com
www.imetsaws.com

MACHINE MODEL

KTECH 352 F1200

Automatic bandsaw for structural steels

Short description

KTECH 352 F1200 is a pivoting bandsaw with automatic NC rotation and integrated 1200mm motorized feeder intended to be used for structural steels and steel works factories. The machine is equipped with an easy and intuitive HMI by 10" touch screen display and can provide a cutting range from +60° to -45°. Full compatibility with Industry 4.0 system.

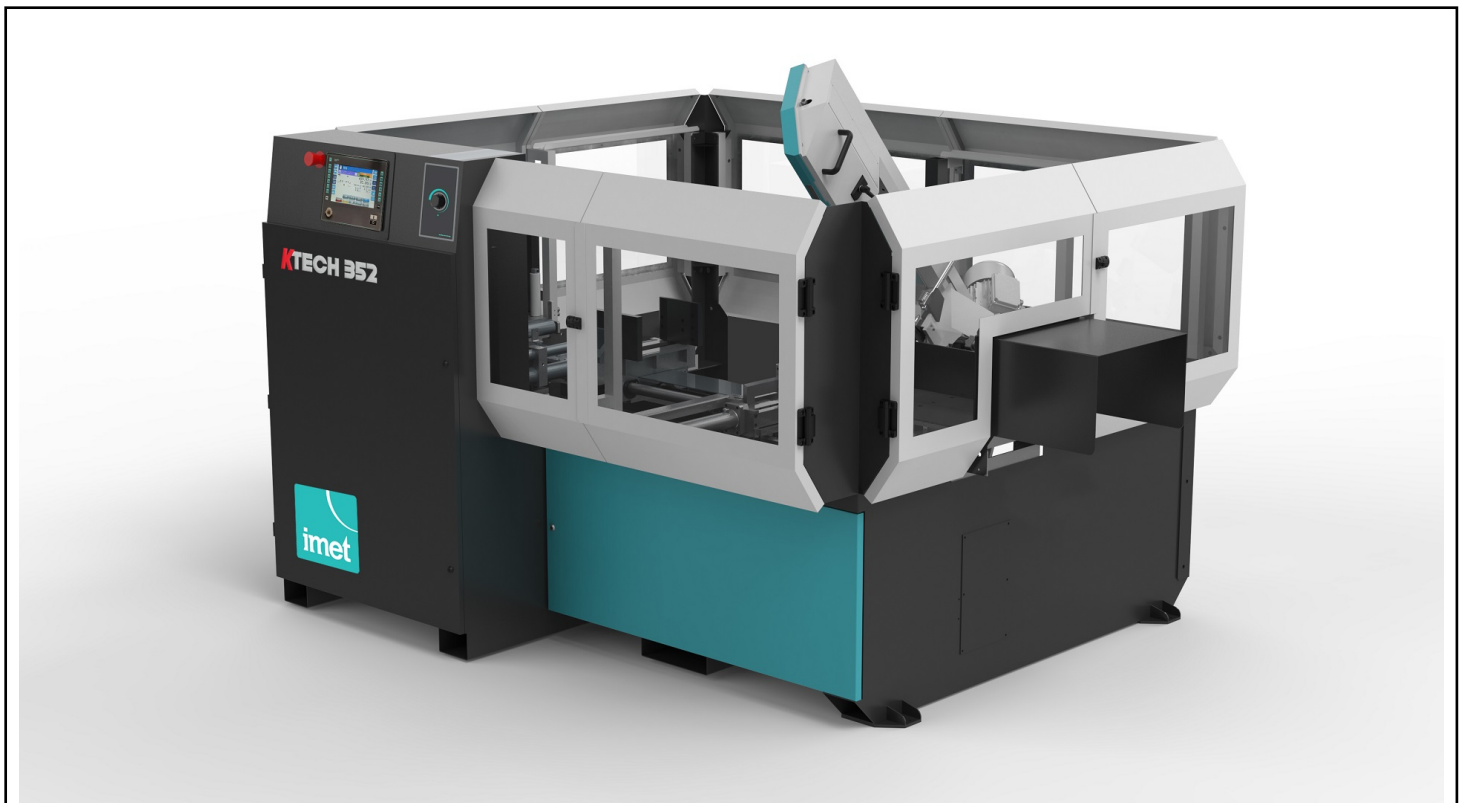

Cutting capacity at 0°	Round: 305mm - Square: 250mm - Rectangular: 350x200mmm
Cutting capacity at 45° left/right	Round: 255mm - Square: 230mm - Rectangular: 230x200mmm
Cutting capacity at 60° left	Round: 175mm - Square: 155mm - Rectangular: 170x100mmm
Cutting capacity with bundle device	Max 300x160mm - Min 85x10mm
Cutting capacity at 0° - solids (C45)	200mm
Minimum cutting length	20mm
Minimum cutting diameter	20mm
Minimum scrap-end	150mm
Blade size	3370x27x0.9mm
Blade motor	1.8KW
Blade speed range	15-100 m/min
Feeder (single stroke)- motor power	1150mm with ballscrew - 0.75KW
Hydraulic unit tank capacity	20l
Coolant tank	100l
Machine size	2935x2400x1900mm - 2100kg



Features



HMI 10" touch screen

KTECH 352 has an easy and intuitive interface dedicate to optimize the user-experience: thanks the CNC system and 10" touch screen display the user can manage all the machine operative function, set up 99 cutting program and multiple cutting length on the same bar, set the number of feeder stroke, the number of pieces and blade speed. It's also possibile to do an autodiagnostic to detect errors.

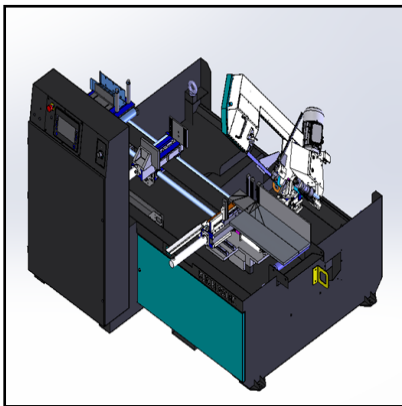

NC control

KTECH line automatic bandsaws have an innovative 4 controlled axis system (lateral movement and closing of the vice, material feeding and sawframe rotation), all managed by numeric control. All the machine movement and setting can be controlled and modified via touch screen display.



Sawframe

The bow is made with electrowelded steel and has tubular section, big diameter pulleys (380mm) with hinged blade-cover carter. The sawframe also has an easy blade-changing system provided by support piston. Hard metal pads on mobile blade-guides optimize the blade alignment.



Blade and endcutting

KTECH 352 uses a 27x0.9mm blades with high working tension (up to 1900kg/cm²) that gives high results in terms of material feeding and cutting, allowing to reduce vibrations and strain on the band and avoid breakages that could damage the cutting quality. As all Imet machine, also this model ends the cut with the blade not in parallel with the plate: this systems allows to cut always only a section of the material even when working with squares.

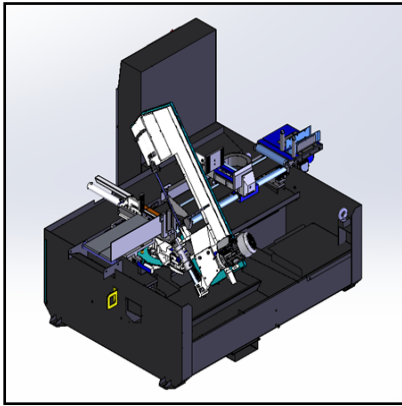

Sawframe movement

Sawframe rotation and angle setting position is managed by motoreducer controlled by inverter and it's provided by rack and pinon. The rotation is blocked by an hydraulic cylinder once the set angles is correct. The machine automtically synchronized the bow rotation with the vice closing and movement. Descent is hydraulic with pressure regulators on the mobile panel control, next to the HDI system.



Mechanical detection device

Mechanical material detection system automatically detech the first point point, allowing the fast approach of the bow to the material. The end-cutting process is managed by a microswitch placed on the mobile blade guides that automatically detech when the cutting process ends.

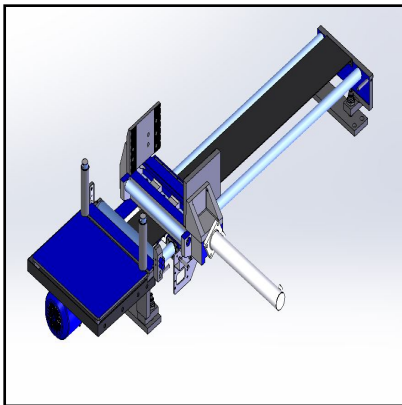

F1200 integrated feeder

Once loaded, the material movement is provided by the integrated motorized feeder equipped with self-braking electric motor, incremental screw (that also optimizes to have perfect positioning and accuracy), inverter and encoder. The feeder slides on chromed bars with a floating plate to ease the loading of material that is not perfectly straight.

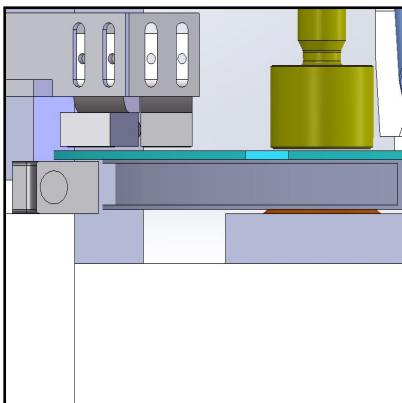

Cutting precision

KTECH line bandsaws have an automatic control of the pieces size thanks to the infinitesimal encoder and the automatic correction of the cutting lengths. Thanks to the innovative angle measurement system (angle reading is set outside the machine center), the machine has an high positioning accuracy and the best cutting precision.



IMET SPA
Località tre fontane, 6 - 24034
Cisano Bergamasco (BG) Italy
Tel +39 035 4387911 | Fax +39 035 787066
imet@imetsaws.com
www.imetsaws.com

KTECH 352 F1200



Industry 4.0 Ready - SAWfactory + RealTime

OPTIONAL

IMET automatic machines can be connected to the company network and be used remotely thanks SAWFACTORY and modem. SAWFACTORY is a dedicated software which allows to manage the cutting process from the office desk by setting cutting programs and monitoring the workflow thanks to the dedicated web app. The software also allows to also receive assistance by our technicians remotely. Discover SAWFACTORY: <https://bit.ly/2RuxHuX>



Industry 4.0 - RealTime Kit for

OPTIONAL

The kit allows to send directly from the machine to the MES information in real time about: machine status, cut pieces situation, automatic cycle progression. The connection is provided via a Web service made available by the user on his own LAN; the webservice will act as a filter between the bandsaw and the internal MES (the kit is available only if the "Industry 4.0 Ready" package is already installed)



Industry 4.0 Ready - OneLoad Kit for MES

OPTIONAL

The kit allows to load from the company office/MES to the machine software a cutting list/program to optimize the internal workflow while avoiding possible mistakes made by the machine operator. It's necessary, for the customer, to have an FTP server on the same LAN where both SAWprogram software and cutting program are installed. A "shortcut" is enabled on the machine control to load the cutting lists and start the cycle (the kit is available only if the "Industry 4.0 Ready" package is already installed).

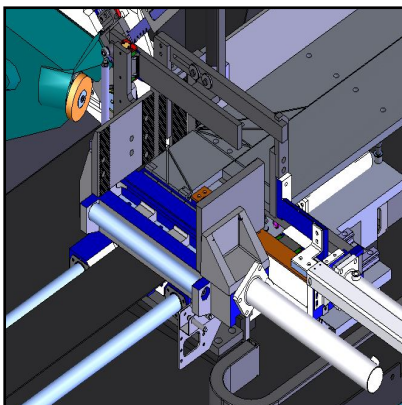

Bundle device

OPTIONAL

The bundle device is made two groups of pressers: one mounted on the fixed vice, the other on the rear vice. It can only be used for 0° cutting. Single piece capacity with mounted device: 350x160mm max, min. 55x10mm. Cutting capacity for bundle is: max 300x160mm, minimum 85x10mm. The device can be disassembled using the 2 screws on fixed vice and the 2 on the carriage vice and disconnecting the hydraulic tubes using the quick couplings systems. Not compatible with laser ray (only one can be put on the same machine).



Laser ray **OPTIONAL**

Mounted on the sawframe, the system gives the user the possibility to visualize the cutting line on the material during the sawframe descent.



Minimal lubrication device **OPTIONAL**

It is possible to request for any machine the minimum lubrication which eliminates the dispersion of coolant typical in the use of emulsifiable oil, the duration of the blade is in no way affected.



Motorized chips conveyor **OPTIONAL**

To ease the machine working cycle, it's possible to add on the machine a motorized chips conveyor on the lateral side of the machine. The chip conveyor allows to optimize the machine efficiency by removing chips from the working area and tanks to keep the area clean, allowing to have an optimized workflow.

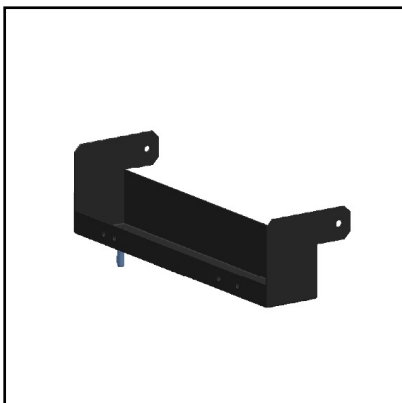

Connection element for roller tables **OPTIONAL**

To connect the machine to the roller table, it must be added the connection element



Roller tables

OPTIONAL

It's possible to integrate the machine with free rolls table both on loading and unloading side. Each module has 2m length and it's equipped with 7 supporting rollers (d. 60mm). The first element (which is connected to the machine) has 2 supporting pedestals while the following elements are equipped with 1 pedestal.



Vertical rollers

OPTIONAL

Pair of vertical steel containment rollers. Maximum 2 couples; single element 2m. To be used without roller cover.

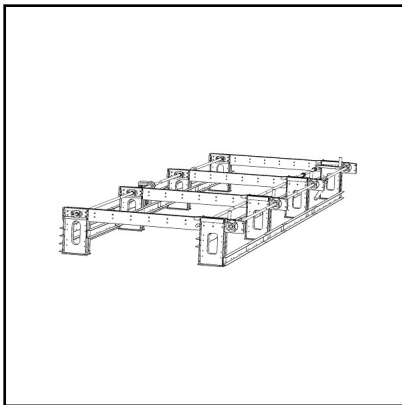

Automatic loading system

OPTIONAL

Automatic bar loader driven by the saw control software where the bars are automatically fed, consisting of supporting surfaces with a drag chain and loading stations (from 5 to 15). The supporting surfaces can be easily moved thanks to a modular structure. The feeder is provided with a system of blockage of the bar and with vertical aligning rollers and gearboxes to move the drag chains. The system is driven by the software of the saw to which it is connected.



Automatic unloading system

OPTIONAL

The bandsaw can be integrated also with different kinds of automatic unloading systems, depending on material size and customer's requests. The system always works in synchro with the material feeder and sawframe movement. The unloading process can be provided by a simple tilting table that separate good pieces and scrap- ends/trim cuts (firsts on one side, seconds on the other) or by an expulsion of the cut pieces provided by a laterail pusher system (that can be coupled with motorized carpet, motorized table or free table).